

To Print: Click your browser's PRINT button.

NOTE: To view the article with Web enhancements, go to:

<http://www.medscape.com/viewarticle/543611>

What is Intervertebral Disc Degeneration, and What Causes It?

Michael A. Adams, PhD; Peter J. Roughley, PhD

Spine. 2006;31(18):2151-2161. ©2006 Lippincott Williams & Wilkins
Posted 09/19/2006

Abstract and Introduction

Abstract

Study Design: Review and reinterpretation of existing literature.

Objective: To suggest how intervertebral disc degeneration might be distinguished from the physiologic processes of growth, aging, healing, and adaptive remodeling.

Summary of Background Data: The research literature concerning disc degeneration is particularly diverse, and there are no accepted definitions to guide biomedical research, or medicolegal practice.

Definitions: The process of disc degeneration is an aberrant, cell-mediated response to progressive structural failure. A degenerate disc is one with structural failure combined with accelerated or advanced signs of aging. Early degenerative changes should refer to accelerated age-related changes in a structurally intact disc. Degenerative disc disease should be applied to a degenerate disc that is also painful.

Justification: Structural defects such as endplate fracture, radial fissures, and herniation are easily detected, unambiguous markers of impaired disc function. They are not inevitable with age and are more closely related to pain than any other feature of aging discs. Structural failure is irreversible because adult discs have limited healing potential. It also progresses by physical and biologic mechanisms, and, therefore, is a suitable marker for a degenerative process. Biologic progression occurs because structural failure uncouples the local mechanical environment of disc cells from the overall loading of the disc, so that disc cell responses can be inappropriate or aberrant. Animal models confirm that cell-mediated changes always follow structural failure caused by trauma. This definition of disc degeneration simplifies the issue of causality: excessive mechanical loading disrupts a disc's structure and precipitates a cascade of cell-mediated responses, leading to further disruption. Underlying causes of disc degeneration include genetic inheritance, age, inadequate metabolite transport, and loading history, all of which can weaken discs to such an extent that structural failure occurs during the activities of daily living. The other closely related definitions help to distinguish between degenerate and injured discs, and between discs that are and are not painful.

Introduction

The problem of intervertebral disc degeneration has been approached from many sides, from orthopedic surgery to molecular biology, and the scientific literature on the subject is particularly diverse. Perhaps as a result of this, there is no consensus on what disc degeneration actually is or how it should be distinguished from the physiologic processes of growth, aging, healing, and adaptive remodeling. We suggest that a precise definition of disc degeneration is long overdue. It would focus attention on which degenerative features are most likely to influence patients' prognosis and which are the best targets for therapeutic interventions. It would help epidemiologists identify risk factors for the disease^[1] and suggest improved strategies for prevention. In addition, medicolegal experts would be better able to distinguish between a disease process and normal constitutional changes.

Recently, the relevant research literature has been thoroughly reviewed and summarized,^[2] although no definitions were suggested. At a subsequent symposium in Davos, Switzerland, in 2005, there was widespread agreement that a definition would be beneficial but no agreement on how it should be phrased.^[3] We suggest that the time is right to introduce a working definition of disc degeneration, one which will stimulate further discussion and lead to a formulation that will satisfy most researchers working in the field.

The purpose of the present article is to propose and justify a working definition of intervertebral disc degeneration, and show how it facilitates interpretation of the diverse research literature. Initial sections review the evidence concerning intervertebral disc functional anatomy, metabolism, aging, structural failure, and pain. This review is followed by an account of disc degeneration as suggested by animal models and epidemiology. Finally, 2 interpretation sections consider what disc

degeneration is and what causes it.

Disc Functional Anatomy

Intervertebral discs are pads of fibrocartilage that resist spinal compression while permitting limited movements. They spread loading evenly on the vertebral bodies, even when the spine is flexed or extended. Individual lamellae of the annulus fibrosus consist primarily of collagen type I fibers passing obliquely between vertebral bodies, with orientation of the fibers being reversed in successive lamellae (Figure 1). The nucleus pulposus consists of a proteoglycan and water gel held together loosely by an irregular network of fine collagen type II and elastin fibers. The major proteoglycan of the disc is aggrecan,^[5,6] which, because of its high anionic glycosaminoglycan content (*i.e.*, chondroitin sulfate and keratan sulfate), provides the osmotic properties needed to resist compression (Figure 2).

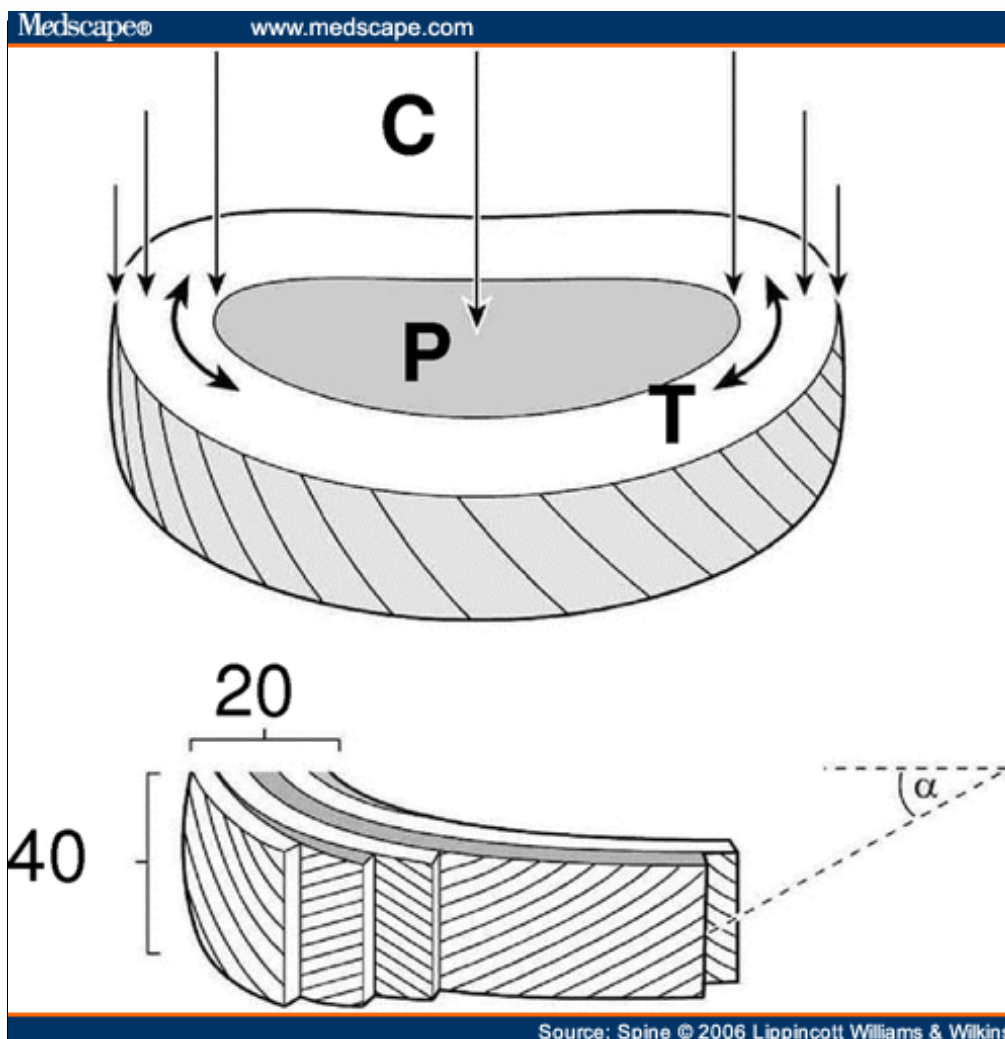

Figure 1.

Intervertebral disc structure and function. **Upper**, spinal compression (C) generates a hydrostatic pressure (P) in the nucleus, and tensile stresses (T) in the annulus. **Lower**, Lamellae of the annulus with oblique collagen fibers in alternating directions (approximately, $\alpha = 30^\circ$). Typical values are given of the number of lamellae in the annulus and the number of collagen fiber bundles in a lamella. Reprinted with permission from Churchill Livingstone; 2002.^[4]

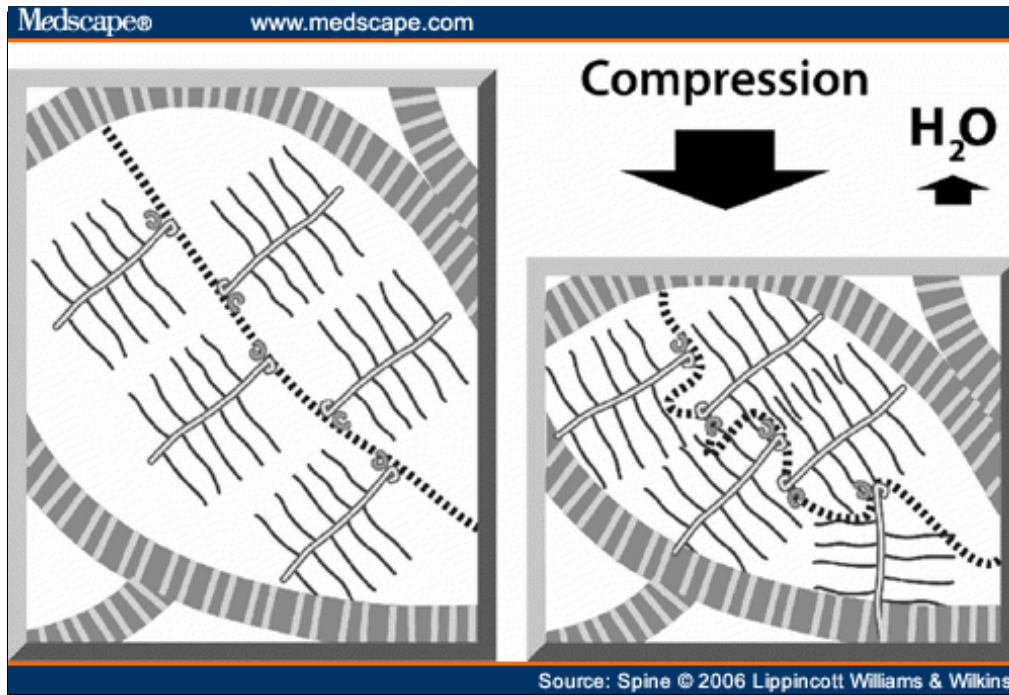

Figure 2.

The role of aggrecan and collagen in the ability of disc to resist compression. The nucleus pulposus is depicted as containing proteoglycan aggregates entrapped in a collagen fiber network. The proteoglycan aggregates are depicted as a central hyaluronan molecule (dashed line) substituted with aggrecan molecules possessing a central core protein (open line) and sulfated glycosaminoglycan side chains (solid lines). The hydration properties of the glycosaminoglycan chains of aggrecan cause the tissue to swell until an equilibrium is reached, in which the swelling potential is balanced by tensile forces in the collagen network. Compressive loading of the spine forces some water from the disc effectively increasing the aggrecan concentration and its swelling potential, and resisting further compression. On removal of the compressive load, disc height is restored as water is drawn back into the tissue to restore the original equilibrium conditions. Any parameter that decreases proteoglycan concentration or weakens the collagen network will be detrimental to disc function.

The internal mechanical functioning of an intervertebral disc can be studied by pulling a miniature pressure transducer through it. A young healthy disc behaves like a water bed, with the high water content of the nucleus and inner annulus enabling the tissue to act like a fluid (Figure 3A). Only the outermost annulus acts as a tensile skin to restrain the nucleus. With increasing age, disc water content decreases, especially in the nucleus, and most of the annulus then acts like a fibrous solid to resist compression directly (Figure 3B). In physically disrupted discs (Figure 3C), regions of fibrous tissue resist mechanical loading in a haphazard manner, and the hydrostatic nucleus is reduced or absent.

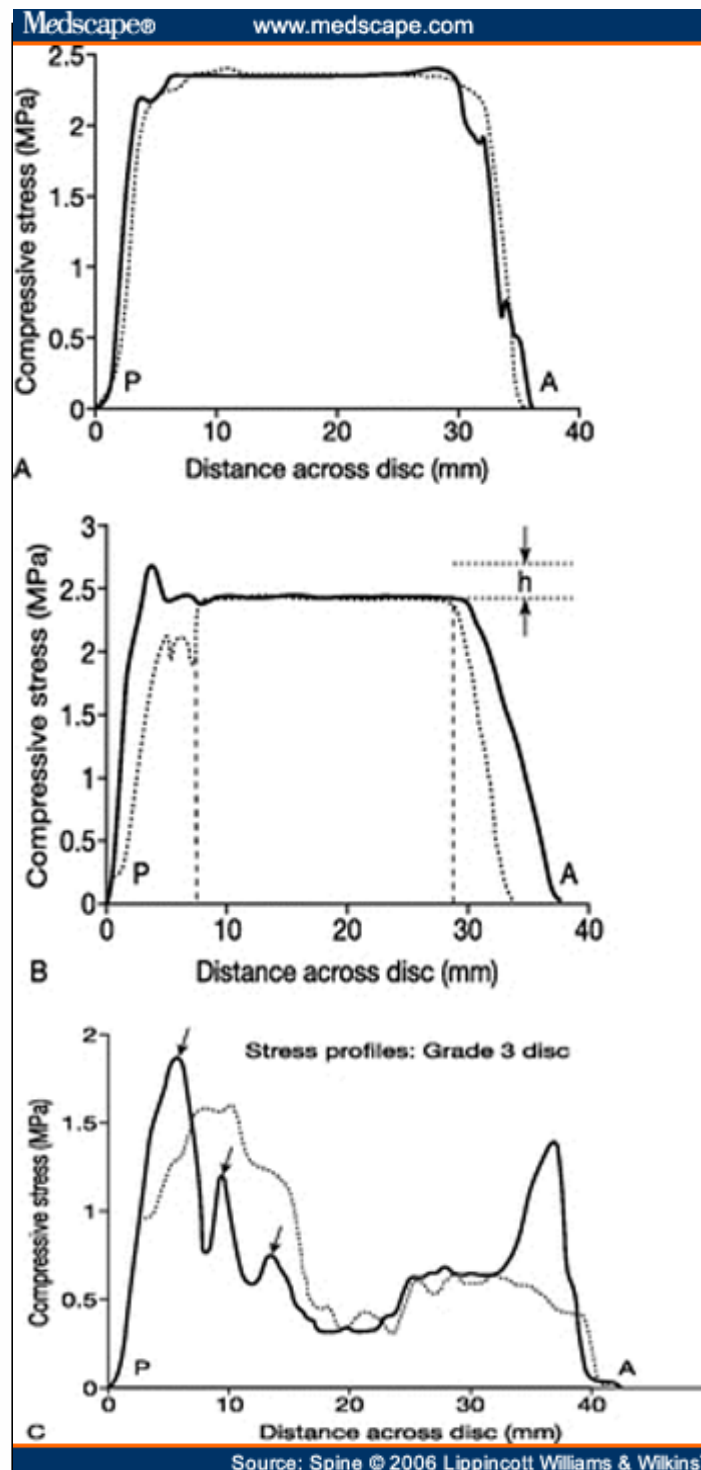

Figure 3.

Stress profiles showing the distribution of compressive stress across the midsagittal diameter of lumbar intervertebral discs subjected to 2 kN of compression. Vertical and horizontal stresses are indicated in solid and broken lines, respectively. (A) Young Grade 1 disc. (B) Middle-aged Grade 2 disc, showing a stress concentration of magnitude h in the posterior annulus. The hydrostatic functional nucleus lies between the 2 vertical dashed lines. (C) Degenerated Grade 3 disc with multiple stress concentrations in the annulus (arrow). Compare with Figure 6. Reprinted with permission from Churchill Livingstone; 2002.^[4]

Disc Metabolism

Disc Cells

Cells in the annulus are elongated parallel to the collagen fibers, rather like fibroblasts. Cells in the nucleus are initially notochordal but are gradually replaced during childhood by rounded cells resembling the chondrocytes of articular cartilage.

Anulus cells synthesize mostly collagen type I in response to deformation, whereas nucleus cells respond to hydrostatic pressure by synthesizing mostly proteoglycans and fine collagen type II fibrils. Cell density declines during growth,^[7] and in the adult is extremely low, especially in the nucleus. Disc cell biology has been reviewed recently.^[8,9]

Metabolite Transport

In adult discs, blood vessels are normally restricted to the outmost layers of the annulus. Metabolite transport is by diffusion, which is important for small molecules, and by bulk fluid flow, which is important for large molecules.^[8,10] Transport routes are shown in Figure 4. Low oxygen tension in the center of a disc leads to anaerobic metabolism, resulting in a high concentration of lactic acid and low pH.^[8] *In vitro* experiments show that a chronic lack of oxygen causes nucleus cells to become quiescent, whereas a chronic lack of glucose can kill them.^[12] Deficiencies in metabolite transport appear to limit both the density and metabolic activity of disc cells.^[8] As a result, discs have only a limited ability to recover from any metabolic or mechanical injury. Endplate permeability and, therefore, disc metabolite transport normally decrease during growth and aging, and yet increase in the presence of disc degeneration and following endplate damage.^[13] This is one essential difference between aging and degeneration.

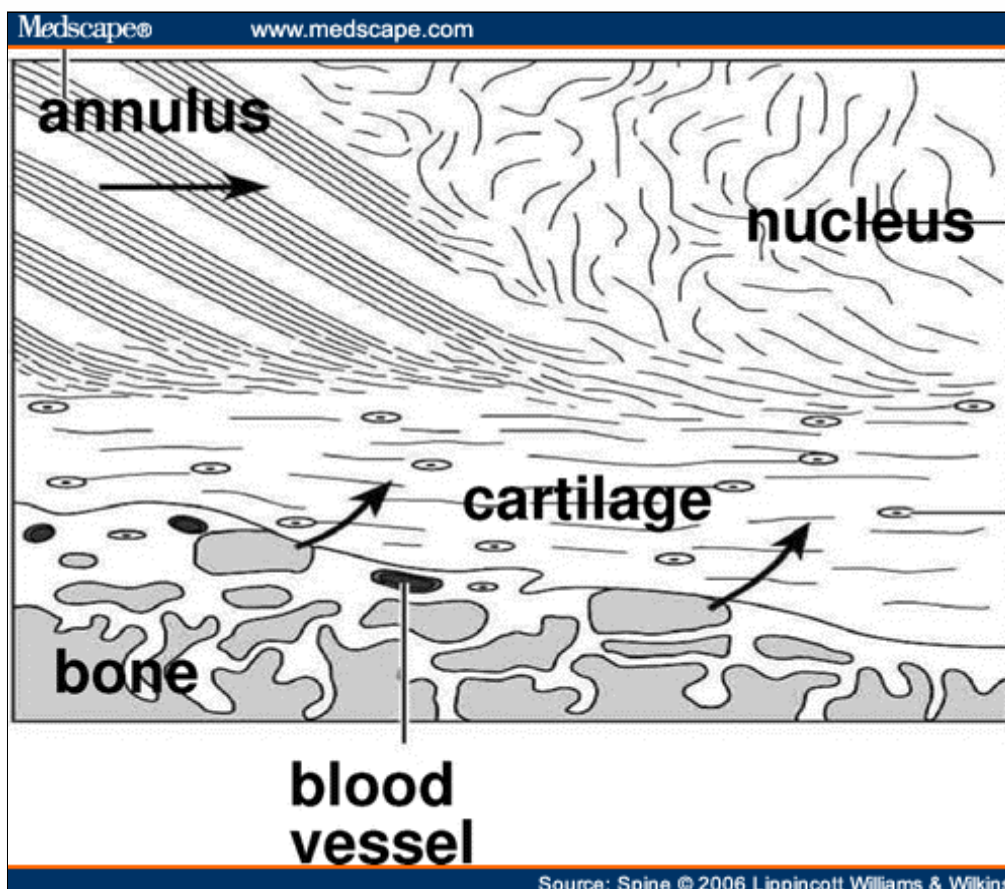

Figure 4.

Organization of the vertebral endplate. The vertebral endplate consists of hyaline cartilage weakly bonded to the perforated cortical bone of the vertebral body, and collagen fibers of the annulus and nucleus. Arrows indicate routes for nutrient transport from surrounding blood vessels into the central regions of the disc. Adapted from *J Orthop Res* 1993;11:747-57.^[11]

Growth and Adaptive Remodeling

Disc cells synthesize their matrix and break down existing matrix by producing and activating degradative enzymes, including matrix metalloproteinases (MMPs) and a disintegrin and metalloproteinase (ADAMS).^[14-20] Molecular markers of matrix turnover are naturally most plentiful during growth but usually decline thereafter.^[21] The major structural changes to the disc occur during fetal and juvenile growth, when the nucleus changes in consistency from a translucent fluid to a soft amorphous tissue,^[22] caused mainly by an increase in collagen content. The proteoglycan content of the disc is maximal in the young adult and declines thereafter,^[21] presumably because of proteolysis. Disc cells appear to adapt the properties of their matrix to suit prevailing mechanical demands, although the low cell density and lack of a blood supply ensure that changes are not as rapid or pronounced as in adjacent vertebrae.^[23] Adaptive remodeling probably contributes to the large variation in compressive strength of adult discs, which ranges from 2.8 to 13.0 kN when they are tested in a manner that

causes failure in the disc rather than the adjacent vertebra.^[24]

Disc Healing

Injured discs show increased levels of catabolic cytokines, increased MMP activity,^[21,25] and scar formation,^[26] especially in the vicinity of annular tears.^[26,27] They also show evidence of renewed matrix turnover^[21,28] and a more variable range of collagen fibril diameters.^[29] However, gross injuries to a disc never fully heal. Scalpel cuts in the outer annulus fill with granulation tissue, with only the outer few millimeters being bridged by scar tissue.^[30,31] Annular tears are not remodeled as in bone, presumably because the sparse cell population is unable to break down the large collagen fiber bundles of the annulus and replace them with new.^[32] Collagen turnover time in articular cartilage is approximately 100 years^[33] and could be even longer in the disc. Proteoglycan turnover is faster, possibly 20 years,^[32] and some regeneration of nucleus pulposus is possible in young animals.^[34] Injuries that affect the inner annulus or endplate decompress the nucleus,^[35] and healing processes are then overtaken by severe degenerative changes.^[31]

Disc Aging

Biochemical Changes

Proteoglycan fragmentation starts during childhood,^[36] and with increasing age, the overall proteoglycan and water content of the disc decreases, especially in the nucleus.^[21] There is a corresponding increase in collagen content, a tendency for fine type II collagen fibrils in the inner annulus to be replaced by type I fibers as the annulus encroaches on the nucleus, and for type I fibers throughout the disc to become coarser. Loss of proteoglycan fragments from the disc is a slow process owing to the entrapment of the nucleus by the fibrous annulus and the cartilage endplates of the vertebrae.^[37] As long as the proteoglycan fragments remain entrapped in the disc, they can fulfill a functional role similar to that of the intact proteoglycan. Reduced matrix turnover in older discs enables collagen molecules and fibrils to become increasingly cross-linked with each other, and existing cross-links become more stable.^[28] In addition, reactions between collagen and glucose lead to nonenzymatic glycation (extra cross-links that give old discs their characteristic yellow-brown appearance).^[38] Increased cross-linking inhibits matrix turnover and repair in old discs, encouraging the retention of damaged macromolecules^[32] and probably leading to reduced tissue strength.

Histologic Changes

During early childhood, the blood supply to the vertebral endplate decreases, and microstructural clefts and tears become common by the age of 15 years, especially in the nucleus and endplate.^[39] Cell density decreases throughout growth,^[7] and from skeletal maturity onward, there is a steadily increasing incidence of structural defects extending into the annulus.^[26] The nucleus pulposus tends to condense into several fibrous lumps, separated from each other and from the cartilage endplate by softer material.^[40] Sequential histologic changes across 9 decades have recently been classified.^[39] Generally, these changes affect the endplate first, then the nucleus, and, finally, the annulus, and different spinal levels are affected to a similar extent.

Metabolic Changes

Matrix synthesis decreases steadily throughout life but sometimes increases again in old and severely disrupted discs.^[21] Reduced synthesis is partly attributable to decreased cell density, although proteoglycan synthesis rates per cell also decrease.^[41] Cell proliferation can occur locally in association with fissures and increased MMP activity.^[26,27] Age-related changes in the types of collagens and MMPs synthesized suggest that cell phenotype can change,^[27] possibly in response to altered matrix stress distributions (Figure 3).

Functional Changes

With increasing age, the hydrostatic nucleus becomes smaller and decompressed, and so more of the compressive load-bearing is taken by the annulus (Figure 3B).^[42] To fulfill this functional demand, the inner annulus of the young adult possesses a relatively high proteoglycan content.^[21] However, with increasing age, the proteoglycan content decreases, and the annulus becomes stiffer and weaker.^[43] Disc height does not show a major decrease with age,^[44] although degenerative changes can cause the annulus to collapse in some old discs (see later).

Disc Structural Failure

Annulus Tears

There are 3 types of tears that can be distinguished: circumferential tears or delaminations, peripheral rim tears, and radial fissures (Figure 5). They become increasingly common after the age of 10 years,^[39] especially in the lower lumbar spine, and reach a peak in middle age.^[45] Circumferential tears may represent the effects of interlaminar shear stresses,^[46] possibly occurring from compressive stress concentrations in older discs (Figure 3). Peripheral rim tears are more frequent

in the anterior annulus^[47] and may be associated with bony outgrowths.^[48] Mechanical^[4] and histologic^[47] considerations suggest that they are related to trauma. Radial fissures progress outward from the nucleus, usually posteriorly or posterolaterally,^[47] and this process can be simulated in cadaveric discs by cyclic loading in bending and compression.^[4] Radial fissures are associated with nucleus degeneration,^[47,49] but it is not clear which comes first. The 3 types of annulus tear probably evolve independently of age and each other.^[50]

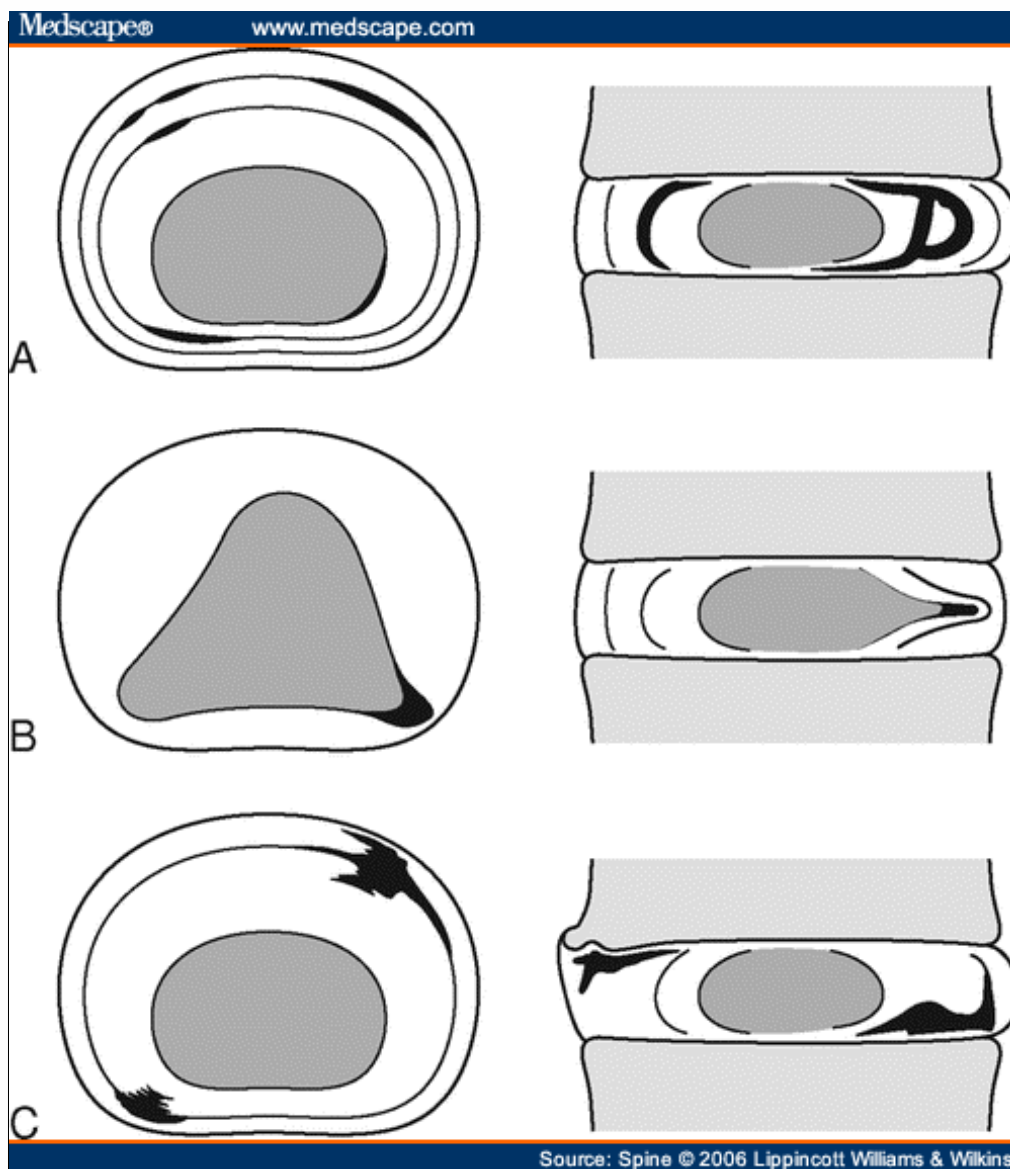

Figure 5.

Three common types of annulus tears. **A**, Circumferential clefts or delamination. **B**, Radial fissure. **C**, Peripheral rim lesion. Disrupted tissue is shown in black, and nucleus pulposus is shaded. Images are in the transverse plane (left) and sagittal plane (right). Reprinted with permission from Churchill Livingstone; 2002.^[4]

Disc Prolapse

When radial fissures allow gross migration of nucleus relative to annulus, to the extent that the disc periphery is affected, then the disc can be said to be herniated, or prolapsed. Depending on the extent of nucleus migration, the disc herniation may result in protrusion, extrusion, or sequestration of the nuclear material. Disc prolapse can be simulated in cadaveric discs by combined loading in bending and compression, with either one component exceeding physiologic limits,^[24,35] or as a result of intense repetitive loading.^[51,52] Mechanically induced prolapse (Figure 6E) occurs most readily in discs aged 30-40 years,^[24,53] which presumably still have a fluid nucleus and an annulus starting to become weakened by age. Severely degenerated discs do not prolapse in the laboratory, presumably because the nucleus is no longer able to exert a hydrostatic pressure to tension the annulus. In living people, prolapsed disc tissue consists primarily of nucleus pulposus displaced down a radial fissure.^[54]

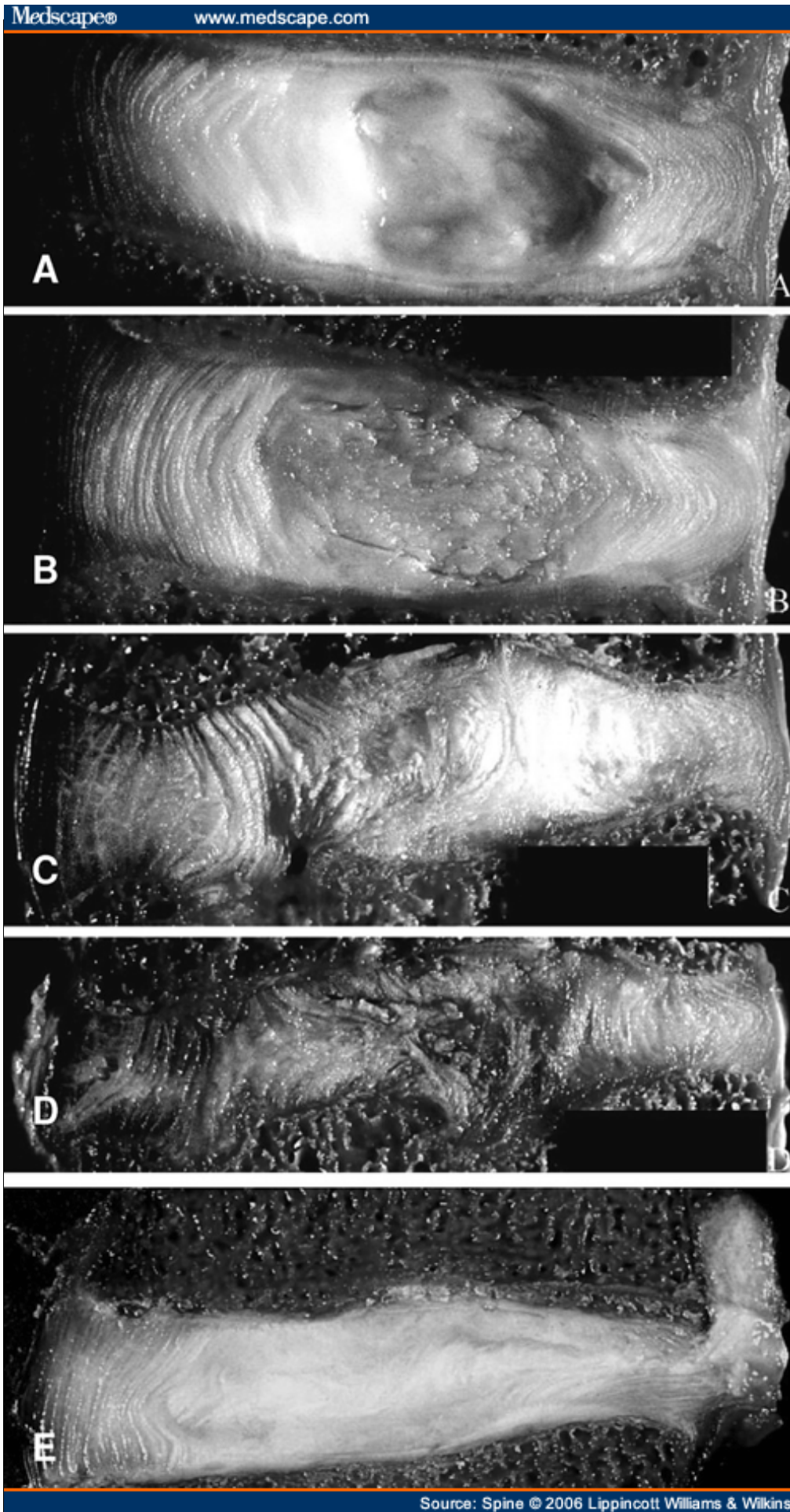

Figure 6.

Cadaveric lumbar intervertebral discs sectioned in the midsagittal plane (anterior on left). (A) Young disc

(male, 35 years old). (B) Mature disc (male, 47 years old). (C) Disrupted young disc (male, 31 years old). Note the endplate damage and inward collapse of the inner annulus. (D) Severely disrupted young disc (male, 31 years old). Note the collapse of disc height. (E) Disc induced to prolapse in the laboratory (male, 40 years old). Some nucleus pulposus has herniated through a radial fissure in the posterior annulus (right). Discs (A-D) correspond to the 4-point scales typically used to grade disc degeneration from macroscopic features. Reprinted with permission from Churchill Livingstone; 2002.^[4]

Endplate Damage and Schmorl Nodes

Vertebral endplates (Figure 4) are the spine's weak link in compression, and accumulating trabecular microdamage^[55] probably explains why the nucleus increasingly bulges into the vertebral bodies in later life.^[56] Endplate damage immediately decompresses the adjacent nucleus and transfers load onto the annulus, causing it to bulge into the nucleus cavity (Figure 6C).^[35,57] If nucleus pulposus herniates through a damaged endplate, then subsequent calcification can create a Schmorl's node.

Internal Disc Disruption^[58]

Collapse of the inner annulus into the nucleus is a common feature of elderly discs (Figures 6C, D), with the anterior annulus being affected more than the posterior.^[59,60] It could be caused by nucleus decompression following endplate fracture, as described previously. In many elderly discs, the cartilage endplate becomes detached from underlying bone,^[60] presumably because the high internal pressure that presses it against the bone in young discs has been lost.

Disc Narrowing, Radial Bulging, and Vertebral Osteophytes

These 3 features are closely associated with one another and with the term spondylosis (Figure 7). With increasing age, the nucleus tends to bulge into the vertebral bodies. Nucleus pressure is reduced,^[61,62] and increased vertical loading of the annulus⁶¹ causes it to bulge radially outward,^[63] and sometimes inward. Severe changes are accompanied by a marked loss of nucleus pressure^[62] and collapse of annulus height (Figure 6D). In effect, the disc behaves like a flat tire.^[63] It is annulus height that determines the separation of adjacent neural arches, and annulus collapse/bulging in old discs can lead to more than 50% of the compressive force on the lumbar spine being resisted by the neural arch.^[64] This effect probably explains why narrowed discs are associated with osteoarthritis in the apophyseal joints and with osteophytes (Figure 7) around the margins of the vertebral bodies.^[65]

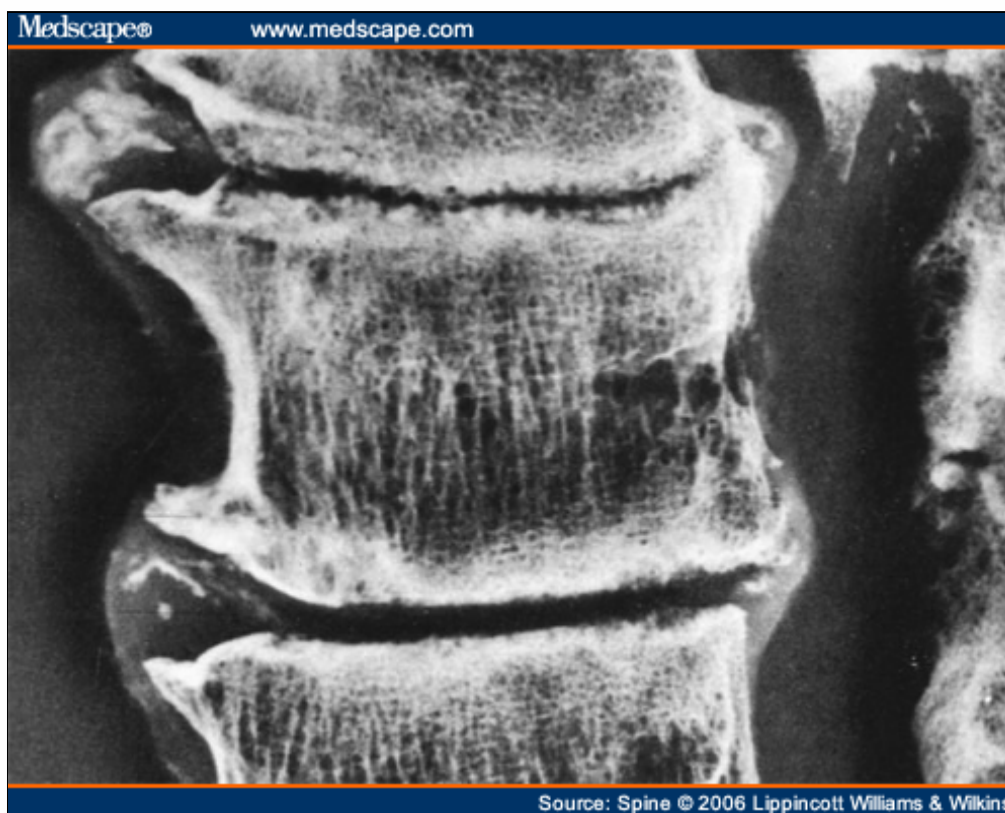

Figure 7.

Radiograph of an old cadaveric lumbar spine (anterior on left). The radiograph depicts how severe disc

narrowing can be associated with vertebral osteophytes, sclerosis of the vertebral endplates, and selective loss of horizontal trabeculae from the vertebral body. Reprinted with permission from Churchill Livingstone; 2002.^[4]

Discogenic Pain

The posterior anulus and its adhering longitudinal ligament are supplied by the sinuvertebral nerve, a mixed autonomic and somatic nerve believed capable of nociception, whereas the anterior and lateral regions are supplied by autonomic nerves.^[66] Nociceptive nerve fibers normally penetrate only the outermost 1-3 mm of anulus^[67,68] but have been reported to progress in toward the nucleus in the anterior regions of painful and severely disrupted discs.^[67] The bony vertebral endplate has a similar density of innervation.^[69]

Pain provocation studies associate severe back pain with relatively innocuous mechanical stimulation of the outer posterior anulus and endplate.^[70] Painful discs are always structurally disrupted^[67] and show irregular stress concentrations.^[71] They appear to become sensitized to mechanical loading, and animal experiments have confirmed that contact with nucleus pulposus can lower nerve stimulation thresholds in adjacent tissues.^[72] Pain sensitization is of most functional significance when it occurs in the outer anulus fibrosus because that is where the highest stress concentrations are found in degenerated discs (Figure 3C).

Features of discs most closely associated with pain include disc prolapse,^[49] disc narrowing,^[73,74] radial fissures,^[73,75] especially when they reach the disc exterior and leak,^[76] and internal disc disruption, including inward collapse of the anulus.^[77] More variably related to pain are endplate fracture and Schmorl nodes,^[78] and disc bulging.^[49,73,78,79] Disc signal intensity on magnetic resonance imaging (MRI) has little if any relationship to pain.^[73]

Disc Degeneration: Animal Models

Animal models provide a reliable guide to biologic processes within degenerating discs because they preserve the complex mechanical and biochemical environment of disc cells. However, they are less useful for investigating how degenerative changes are initiated in human beings because the interventions (or genetic defects) may not represent common occurrences in living people. Small animal models of disc degeneration have some additional limitations relating to their increased cell density, improved metabolite transport, and the presence of notochordal cells in the mature nucleus.^[80] These differences can result in an increased propensity for disc repair.

Surgical disruption of the endplate or anulus leads inexorably to degenerative changes throughout the disc.^[57,81] Perforation of the endplate from the side of the vertebral body causes nucleus decompression, proteoglycan loss, and internal disruption of the anulus.^[57] The anulus disruption model, which simulates a peripheral rim tear, causes subsequent changes in the nucleus and endplate,^[30,81,82] and shows that degenerative changes, unlike aging, need not start in the nucleus. Compressive loading of rodent tail discs can result in cell death, impaired matrix synthesis, and disruption of the anulus and vertebral body.^[83-85] Compression without immobilization affects disc cell metabolism and matrix composition but does not lead to any architectural degenerative changes.^[86] Injecting cement into the vertebral body to block nutrient transport through the endplate does not lead to disc degeneration within 1 year.^[87]

The time span for detectable degenerative changes to occur ranges from 1 week for mice⁸⁸ to many months for pigs and sheep.^[57,81] For comparison, in human adolescents, it takes several years for disc degeneration to become apparent after endplate injury,^[89] and narrowing in adult human discs progresses at approximately 3% per year.^[74]

Disc Degeneration: Epidemiology

Regardless of which definition is used, disc degeneration increases with age and is most common in the lower lumbar spine.^[65] The highest risk factor is genetic inheritance, which accounts for approximately 50-70% of the variability in disc degeneration between identical twins.^[1m90] It is noteworthy that this 50-70% does not include the strong intrasubject dependence of disc degeneration on spinal level, which probably reflects environmental influences.^[1] Individual genes associated with disc degeneration include those for collagen type IX,^[91] aggrecan,^[92] vitamin D receptor,^[93] MMP3,^[94] and cartilage intermediate layer protein.^[95] The products of these genes probably affect the strength of skeletal tissues, and their systemic effects may explain why disc degeneration is more prevalent in those with osteoarthritis.^[74] Environmental risk factors for disc degeneration include high and repetitive mechanical loading^{1,}^[96] and smoking cigarettes.^[97] Disc prolapse is closely associated with heavy lifting,^[98] but not with other features of spinal degeneration or age,^[65] suggesting that prolapse is not an integral part of the aging process.

Interpretation: What is Disc Degeneration?

The aforementioned evidence shows that many different influences are at work in old and degenerating discs, including

genetic inheritance, impaired metabolite transport, altered levels of enzyme activity, cell senescence and death, changes in matrix macromolecules and water content, structural failure, and neurovascular ingrowth. Is it possible to use one or more of these processes to define disc degeneration? To be useful, the definition should be unambiguous and easy to apply to the discs of living people. It should be distinguishable from the inevitable and physiologic processes of growth, aging, and adaptive remodeling. It should be clinically relevant in terms of dysfunction or pain, and it should be consistent with the normal usage of declining to a lower or worse stage of being.^[99] An unfavorable genetic inheritance is present from birth, and yet disc degeneration becomes common only 40 years later, and then only in lower lumbar discs. This implies that genetic inheritance, including polymorphic variations in susceptibility genes, is only a risk factor for future environmentally triggered events and does not in itself constitute disc degeneration.

Inadequate metabolite transport appears to be an inevitable consequence of growth and probably has little direct clinical relevance because it mostly affects the nucleus pulposus, which is the region of degenerated discs that is loaded the least (Figure 3C) and has the fewest nerve endings. The fact that endplate damage leads to disc degeneration, even though it enhances metabolite transport into the disc,^[13] suggests that structural damage has the decisive influence on the degenerative process. The animal models of disc degeneration described previously support this inference. Inadequate nutrition may predispose to disc degeneration by compromising a disc's ability to respond to increased loading, or injury.

Certain markers of altered cell metabolism, such as increased cytokine and MMP activity,^[100,101] could be used as a definition. They are associated with structural defects in the disc,^[27] but currently available markers are unable to differentiate degeneration from growth, adaptive remodeling, and healing. Logically, to suggest that cytokines or proteinases cause disc degeneration is equivalent to blaming war on soldiers! Cytokines and proteinases are merely agents of change, rather than causes. The very complexity of connective tissue metabolism suggests that degeneration could occur from a failure to regulate specific proteinase activities.^[94,102] However, it could equally be argued that the redundancy inherent in such a complex system (cells can achieve a given effect by many different methods) ensures that the system is very robust.

Aging causes inevitable and progressive changes in disc matrix composition, which resemble changes in other aging collagenous tissues. Biochemical changes influence tissue stiffness and strength, and some degraded matrix molecules can impair disc cell metabolism.^[103] In addition, some matrix changes are detectable *in vivo* using MRI, manifesting as a dark disc.^[104] However, age-related changes in matrix composition are inevitable, start soon after birth,^[36,39] and are unrelated to pain.^[1] Age-related reductions in endplate vascularity and disc cell density^[7] could simply reflect necessary adaptations to increased mechanical loading at the onset of ambulation, and reduced metabolite transport in a growing disc. The microstructural clefts and tears that appear increasingly during growth may possibly lead to more extensive disruption in later life, but so long as they remain small, they appear to have little effect on the internal mechanical function of the disc.^[61] In addition, they affect all spinal levels to a similar extent, unlike macroscopic changes that occur mostly between L4 and S1.

Ingrowth of nerves and blood vessels is an important feature of structurally disrupted discs, and appears to be directly, though variably, associated with pain.^[67] Ingrowth could be facilitated by the loss of hydrostatic pressure that characterizes internal regions of intact discs (Figure 3) and that would collapse hollow capillaries. Reduced proteoglycan content in old and degenerated discs may also facilitate the ingrowth of nerves and capillaries¹⁰⁵ because aggrecan can inhibit their growth *in vitro*.^[106,107] Whichever mechanism is favored, it is apparent that ingrowth of blood vessels and nerves is too late an event in disc degeneration to be useful as a defining characteristic.

This leaves structural failure as a candidate for defining disc degeneration. We suggest that certain manifestations of structural failure meet all of the aforementioned criteria. They are easily detected, unambiguous markers of impaired disc function that do not occur inevitably with increasing age, and that are more closely related to back pain and sciatica than any other feature of aging or degenerated discs. Structural failure is permanent because adult discs are incapable of repairing gross defects.

Furthermore, structural failure naturally progresses by physical and biologic mechanisms and, therefore, is a suitable marker for a degenerative process. Physically, damage to one part of a disc increases load-bearing by adjacent tissue, so the damage is likely to spread. This principle explains crack propagation in engineering materials and why peripheral rim tears in animal discs progress in toward the nucleus.^[81] Similarly, pathologic radial bulging of a disc progresses because compressive forces act to collapse the bulging lamellae. Biologic mechanisms of progression depend on the fact that a healthy intervertebral disc equalizes pressure within it, whereas a disrupted disc shows high concentrations of compressive stress in the annulus, and a decompressed nucleus (Figures 3C, 8). Reduced nucleus pressure impairs proteoglycan synthesis,^[108] so the aggrecan and water content of a decompressed nucleus would progressively decrease, which is the opposite of what is required to restore normal disc function.

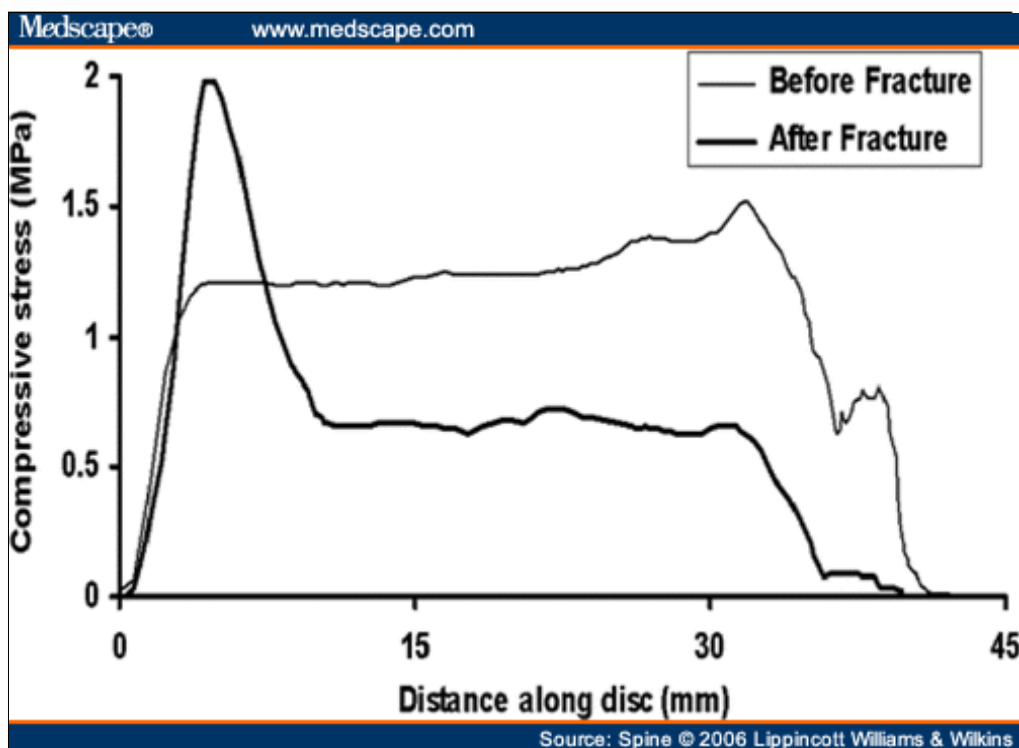

Figure 8.

Stress profiles from a cadaveric lumbar disc showing the distribution of compressive stress across the disc's sagittal midline, before and after fracture of the vertebral endplate. Endplate fracture reduces compressive stress in the anterior and central regions of the adjacent disc, and generates a stress concentration in the posterior annulus^[35] (left).

Similarly, the high stress concentrations generated in the annulus after endplate damage would also be expected to inhibit matrix synthesis and increase production of MMPs.^[109] Therefore, in both regions of the disc, cells would behave inappropriately because structural disruption has uncoupled their local mechanical environment from the overall loading of the disc. Like a collapsed house, a disrupted disc can no longer perform its function, even though its constituent parts remain. Cellular attempts at repair become futile, not because the cells are deficient, but because their local mechanical environment has become abnormal. In this way, structural disruption of the disc progresses by physical and biologic methods, and the process represents degeneration rather than healing.

Defining disc degeneration in terms of structural failure allows all other features of degenerated discs to be considered as predisposing factors for, or consequences of, the disruption. Genetic inheritance and impaired metabolite transport make the disc matrix physically weaker and, so, more vulnerable to injury; so too can age-related changes in collagen cross-linking, and loss of water and proteoglycan from the nucleus. Increased levels of cytokines and MMPs probably reflect the initial features of an attempted repair response to injury, as in other connective tissues, and they could be triggered by the abnormal matrix stresses which follow structural disruption (Figure 8). However, because of impaired matrix synthesis, subsequent repair is never achieved. Transport of catabolic mediators within the disc would also be boosted by the presence of gross fissures, thereby propagating matrix damage. Finally, ingrowth of blood vessels and nerves probably represent a late consequence of altered mechanics and biochemistry in severely degenerated discs. Therefore, defining disc degeneration in terms of structural failure leads to a simple conceptual framework, which incorporates most known features of degenerated discs. It also warns that therapeutic attempts to manipulate disc cell physiology may prove futile unless the cells' mechanical environment is also corrected.

This definition is also consistent with the 4 or 5-point scales conventionally used to grade macroscopic disc degeneration.^[40,110,111] The first point on these scales refers to young and intact discs, while the final point corresponds to end-stage degeneration, typified by a collapse of disc height (Figure 6D). These scales are exercises in pattern recognition, and although useful, they do not explain or define disc degeneration. Previous definitions of disc degeneration are compatible with the definition proposed here: mechanical damage which ... results in a pattern of morphologic and histologic changes;^[112] and sluggish adaptation to gravity loading followed by obstructed healing.^[80] Epidemiologic studies using MRI necessarily equate disc degeneration with associated structural changes.^[1]

An extensive review of nomenclature made clear distinctions between pathologic and age-related changes in discs, and included major structural changes such as radial fissures and disc narrowing in the former category.^[113] Referring to tendon degeneration, Riley *et al*^[102] suggests an active, cell-mediated process that may result from a failure to regulate specific

MMP activities in response to repeated injury or mechanical strain. There is a growing consensus that degeneration involves aberrant cell-mediated responses to progressively deteriorating circumstances in their surrounding matrix.

Therefore, we propose the following definitions. The process of disc degeneration is an aberrant, cell-mediated response to progressive structural failure. A degenerate disc is one with structural failure combined with accelerated or advanced signs of aging. (The second half of this definition distinguishes a degenerate disc from one that has just been injured, and the reference to aging avoids the practical problem of identifying specific cell-mediated responses to structural failure.) Early degenerative changes should refer to accelerated age-related changes in a structurally intact disc. Degenerative disc disease should be applied to a degenerated disc, which is also painful. This last definition is consistent with the widespread use of the word disease to denote something that can cause distress or dis-ease. Manifestations of structural failure such as radial fissures, disc prolapse, endplate damage, internal or external collapse of the anulus, and disc narrowing can themselves be defined in pragmatic terms as is usual in the epidemiologic and radiologic literature.^[65,113,114] Cell-mediated responses to structural failure can be regarded as the final common pathway of the disease process.

Interpretation: What Causes Disc Degeneration?

The aforementioned definitions simplify the issue of causality. Plainly, excessive mechanical loading causes a disc to degenerate by disrupting its structure and precipitating a cascade of nonreversible cell-mediated responses leading to further disruption. As discussed previously, and in detail elsewhere,^[4] cadaveric experiments and mathematical models show how various combinations of compression, bending, and torsion can cause all the major structural features of disc degeneration, including endplate defects, radial fissures, radial bulging, disc prolapse, and internal collapse of the anulus. Injury or wear-and-tear fatigue loading can create damage. Animal experiments confirm that structural disruption to disc or endplate always leads to cell-mediated degenerative changes.

Although we suggest that mechanical loading precipitates degeneration, the most important cause of degeneration could be the various processes that weaken a disc before disruption, or that impair its healing response. The combined effects of an unfavorable inheritance, middle age, inadequate metabolite transport, and loading history appear to weaken some discs to such an extent that physical disruption follows some minor incident. A common example is that of disc herniation following a cough or sneeze. It could be argued that such a weakened disc should be considered degenerated, even if it remains structurally sound. However, a disc is unlikely to become painful until it becomes disrupted, so there is little to be gained by anticipating future events and applying the term degeneration before this crucial nonreversible event actually occurs. As suggested previously, accelerated biochemical or cellular events in a structurally sound disc could be designated early degenerative changes to distinguish them from changes that are entirely typical of the disc's age. The multifactorial nature of disc weakening suggests that, from a medicolegal standpoint, all discs are vulnerable to a greater or lesser extent, and the vulnerability can only be gauged from the violence, or otherwise, required to disrupt the disc and initiate degeneration.

Conclusions

The process of disc degeneration should be defined as an aberrant, cell-mediated response to progressive structural failure. Definitions of a degenerated disc and early degenerative changes should also refer to structural failure, whereas degenerative disc disease should apply to a degenerated disc, which is also painful. The underlying cause of disc degeneration is tissue weakening occurring primarily from genetic inheritance, aging, nutritional compromise, and loading history. The precipitating cause is structural disruption occurring from injury or fatigue failure.

References

1. Battie MC, Videman T, Parent E. Lumbar disc degeneration: Epidemiology and genetic influences. *Spine* 2004;29:2679-90.
2. An HS, Anderson PA, Hughton VM, et al. Introduction: disc degeneration: Summary. *Spine* 2004;29:2677-8.
3. AO Spine research symposium. Spinal motion segment: From basic science to clinical application. July 4-7, 2005; Davos, Switzerland.
4. Adams MA, Bogduk N, Burton K, et al. *The Biomechanics of Back Pain*. Edinburgh, UK: Churchill Livingstone; 2002
5. McDevitt CA. In: Ghosh P, ed. *Biology of the Intervertebral Disc*. Boca Raton, FL: CRC Press; 1988:151-70
6. Watanabe H, Yamada Y, Kimata K. Roles of aggrecan, a large chondroitin sulfate proteoglycan, in cartilage structure and function. *J Biochem (Tokyo)* 1998;124:687-93.
7. Nerlich AG, Weiler C, Weissbach S, et al. Age-associated changes in the cell density of the human lumbar intervertebral disc. Presented at: The 51st Annual Meeting of the Orthopaedic Research Society; Feb 20-23, 2005; Washington, DC
8. Urban JP, Smith S, Fairbank JC. Nutrition of the intervertebral disc. *Spine* 2004;29:2700-9.
9. Setton LA, Chen J. Cell mechanics and mechanobiology in the intervertebral disc. *Spine* 2004;29:2710-23.
10. Ferguson SJ, Ito K, Nolte LP. Fluid flow and convective transport of solutes within the intervertebral disc. *J Biomech* 2004;37:213-21.
11. Roberts S, Menage J, Eisenstein SM. The cartilage end-plate and intervertebral disc in scoliosis: Calcification and other sequelae. *J Orthop Res* 1993;11:747-57.
12. Horner HA, Urban JP. 2001 Volvo Award Winner in Basic Science Studies: Effect of nutrient supply on the viability of cells from the nucleus pulposus of the intervertebral disc. *Spine* 2001;26:2543-9.
13. Rajasekaran S, Naresh Babu J, Arun R, et al. ISSLS prize winner. A study of diffusion in human lumbar discs. *Spine*

- 2004;29:2654-67.
14. Visse R, Nagase H. Matrix metalloproteinases and tissue inhibitors of metalloproteinases: Structure, function, and biochemistry. *Circ Res* 2003;92:827-39.
 15. Mott JD, Werb Z. Regulation of matrix biology by matrix metalloproteinases. *Curr Opin Cell Biol* 2004;16:558-64.
 16. Duffy MJ, Lynn DJ, Lloyd AT, et al. The ADAMs family of proteins: From basic studies to potential clinical applications. *Thromb Haemost* 2003;89:622-31.
 17. Tang BL. ADAMTS: A novel family of extracellular matrix proteases. *Int J Biochem Cell Biol* 2001;33:33-44.
 18. Porter S, Clark IM, Kevorkian L, et al. The ADAMTS metalloproteinases. *Biochem J* 2005;386:15-27.
 19. Roberts S, Caterson B, Menage J, et al. Matrix metalloproteinases and aggrecanase: Their role in disorders of the human intervertebral disc. *Spine* 2000;25:3005
 20. Goupille P, Jayson MI, Valat JP, et al. Matrix metalloproteinases: The clue to intervertebral disc degeneration? *Spine* 1998;23:1612
 21. Antoniou J, Steffen T, Nelson F, et al. The human lumbar intervertebral disc: Evidence for changes in the biosynthesis and denaturation of the extracellular matrix with growth, maturation, ageing, and degeneration. *J Clin Invest* 1996;98:996
 22. Urban JP, Roberts S, Ralphs JR. The nucleus of the intervertebral disc from development to degeneration. *Am Zool* 2000;40:53-61
 23. Adams MA, Dolan P. Could sudden increases in physical activity cause degeneration of intervertebral discs? *Lancet* 1997;350:734-5
 24. Adams MA, Hutton WC. Prolapsed intervertebral disc. A hyperflexion injury 1981 Volvo Award in Basic Science. *Spine* 1982;7:184-91
 25. Kang JD, Georgescu HI, McIntyre-Larkin L, et al. Herniated lumbar intervertebral discs spontaneously produce matrix metalloproteinases, nitric oxide, interleukin-6, and prostaglandin E2. *Spine* 1996;21:271-7.
 26. Nerlich AG, Schleicher ED, Boos N. 1997 Volvo Award winner in basic science studies. Immunohistologic markers for age-related changes of human lumbar intervertebral discs. *Spine* 1997;22:2781-95.
 27. Weiler C, Nerlich AG, Zipperer J, et al. 2002 SSE Award Competition in Basic Science: Expression of major matrix metalloproteinases is associated with intervertebral disc degradation and resorption. *Eur Spine J* 2002;11:308-20.
 28. Duance VC, Crean JK, Sims TJ, et al. Changes in collagen cross-linking in degenerative disc disease and scoliosis. *Spine* 1998;23:2545-51.
 29. Gruber HE, Hanley EN Jr. Ultrastructure of the human intervertebral disc during aging and degeneration: Comparison of surgical and control specimens. *Spine* 2002;27:798-805.
 30. Melrose J, Ghosh P, Taylor TK, et al. A longitudinal study of the matrix changes induced in the intervertebral disc by surgical damage to the annulus fibrosus. *J Orthop Res* 1992;10:665-76
 31. Kaigle AM, Holm SH, Hansson TH. 1997 Volvo Award winner in biomechanical studies. Kinematic behavior of the porcine lumbar spine: A chronic lesion model. *Spine* 1997;22:2796-806.
 32. Roughley PJ. Biology of intervertebral disc aging and degeneration: Involvement of the extracellular matrix. *Spine* 2004;29:2691-9.
 33. Verzijl N, DeGroot J, Thorpe SR, et al. Effect of collagen turnover on the accumulation of advanced glycation end products. *J Biol Chem* 2000;275:39027-31.
 34. Bradford DS, Oegema TR Jr, Cooper KM, et al. Chymopapain, chemonucleolysis, and nucleus pulposus regeneration. A biochemical and biomechanical study. *Spine* 1984;9:135-47.
 35. Adams MA, Freeman BJ, Morrison HP, et al. Mechanical initiation of intervertebral disc degeneration. *Spine* 2000;25:1625-36.
 36. Buckwalter JA. Aging and degeneration of the human intervertebral disc. *Spine* 1995;20:1307-14.
 37. Urban JP, Roberts S. Degeneration of the intervertebral disc. *Arthritis Res Ther* 2003;5:120-30.
 38. DeGroot J, Verzijl N, Wenting-Van Wijk MJ, et al. Accumulation of advanced glycation end products as a molecular mechanism for aging as a risk factor in osteoarthritis. *Arthritis Rheum* 2004;50:1207-15.
 39. Boos N, Weissbach S, Rohrbach H, et al. Classification of age-related changes in lumbar intervertebral discs: 2002 Volvo Award in basic science. *Spine* 2002;27:2631-44.
 40. Adams MA, Dolan P, Hutton WC. The stages of disc degeneration as revealed by discograms. *J Bone Joint Surg Br* 1986;68:36-41.
 41. Maeda S, Kokubun S. Changes with age in proteoglycan synthesis in cells cultured in vitro from the inner and outer rabbit annulus fibrosus. Responses to interleukin-1 and interleukin-1 receptor antagonist protein. *Spine* 2000;25:166-9.
 42. Adams MA, McMillan DW, Green TP, et al. Sustained loading generates stress concentrations in lumbar intervertebral discs. *Spine* 1996;21:434-8.
 43. Ebara S, Iatridis JC, Setton LA, et al. Tensile properties of nondegenerate human lumbar annulus fibrosus. *Spine* 1996;21:452-61.
 44. Frobin W, Brinckmann P, Biggemann M, et al. Precision measurement of disc height, vertebral height and sagittal plane displacement from lateral radiographic views of the lumbar spine. *Clin Biomech (Bristol, Avon)* 1997;12(suppl 1):S1-64.
 45. Hirsch C, Schajowicz F. Studies on structural changes in the lumbar annulus fibrosus. *Acta Orthop Scand* 1953;22:184-231.
 46. Goel VK, Monroe BT, Gilbertson LG, et al. Interlaminar shear stresses and laminae separation in a disc. Finite element analysis of the L3-L4 motion segment subjected to axial compressive loads. *Spine* 1995;20:689-98.
 47. Osti OL, Vernon-Roberts B, Moore R, et al. Annular tears and disc degeneration in the lumbar spine. A post-mortem study of 135 discs. *J Bone Joint Surg Br* 1992;74:678-82.
 48. Hilton RC, Ball J. Vertebral rim lesions in the dorsolumbar spine. *Ann Rheum Dis* 1984;43:302-7.
 49. Jensen MC, Brant-Zawadzki MN, Obuchowski N, et al. Magnetic resonance imaging of the lumbar spine in people without back pain. *N Engl J Med* 1994;331:69-73.

50. Vernon-Roberts B, Fazzalari NL, Manthey BA. Pathogenesis of tears of the anulus investigated by multiple-level transaxial analysis of the T12-L1 disc. *Spine* 1997;22:2641-6.
51. Adams MA, Hutton WC. Gradual disc prolapse. *Spine* 1985;10:524-6.
52. Gordon SJ, Yang KH, Mayer PJ, et al. Mechanism of disc rupture. A preliminary report. *Spine* 1991;16:450-9.
53. Gallagher S. Letter to the editor. *Spine* 2002;27:1378-9.
54. Moore RJ, Vernon-Roberts B, Fraser RD, et al. The origin and fate of herniated lumbar intervertebral disc tissue. *Spine* 1996;21:2149-55.
55. Vernon-Roberts B, Pirie CJ. Healing trabecular microfractures in the bodies of lumbar vertebrae. *Ann Rheum Dis* 1973;32:406-12.
56. Twomey L, Taylor J. Age changes in lumbar intervertebral discs. *Acta Orthop Scand* 1985;56:496-9.
57. Holm S, Holm AK, Ekstrom L, et al. Experimental disc degeneration due to endplate injury. *J Spinal Disord Tech* 2004;17:64-71.
58. Crock HV. Internal disc disruption. A challenge to disc prolapse fifty years on. *Spine* 1986;11:650-3.
59. Gunzburg R, Parkinson R, Moore R, et al. A cadaveric study comparing discography, magnetic resonance imaging, histology, and mechanical behavior of the human lumbar disc. *Spine* 1992;17:417-26.
60. Tanaka M, Nakahara S, Inoue H. A pathologic study of discs in the elderly. Separation between the cartilaginous endplate and the vertebral body. *Spine* 1993;18:1456-62.
61. Adams MA, McNally DS, Dolan P. 'Stress' distributions inside intervertebral discs. The effects of age and degeneration. *J Bone Joint Surg Br* 1996;78:965-72.
62. Sato K, Kikuchi S, Yonezawa T. In vivo intradiscal pressure measurement in healthy individuals and in patients with ongoing back problems. *Spine* 1999;24:2468-74.
63. Brinckmann P, Grootenboer H. Change of disc height, radial disc bulge, and intradiscal pressure from discectomy. An in vitro investigation on human lumbar discs. *Spine* 1991;16:641-6.
64. Pollintine P, Przybyla AS, Dolan P, et al. Neural arch load-bearing in old and degenerated spines. *J Biomech* 2004;37:197-204.
65. Videman T, Battie MC, Gill K, et al. Magnetic resonance imaging findings and their relationships in the thoracic and lumbar spine. Insights into the etiopathogenesis of spinal degeneration. *Spine* 1995;20:928-35.
66. Bogduk N. The innervation of the intervertebral discs. In: Boyling JD, Palastanga N, eds. *Grieve's Modern Manual Therapy-The Vertebral Column*. Edinburgh, UK: Churchill Livingstone; 1994-.
67. Freemont AJ, Peacock TE, Goupille P, et al. Nerve ingrowth into diseased intervertebral disc in chronic back pain. *Lancet* 1997;350:178-81.
68. Palmgren T, Gronblad M, Virri J, et al. An immunohistochemical study of nerve structures in the anulus fibrosus of human normal lumbar intervertebral discs. *Spine* 1999;24:2075-9.
69. Fagan A, Moore R, Vernon Roberts B, et al. ISSLS Prize Winner: The innervation of the intervertebral disc: A quantitative analysis. *Spine* 2003;28:2570-6.
70. Kuslich SD, Ulstrom CL, Michael CJ. The tissue origin of low back pain and sciatica: A report of pain response to tissue stimulation during operations on the lumbar spine using local anesthesia. *Orthop Clin North Am* 1991;22:181-7.
71. McNally DS, Shackelford IM, Goodship AE, et al. In vivo stress measurement can predict pain on discography. *Spine* 1996;21:2580-7.
72. Chen C, Cavanaugh JM, Song Z, et al. Effects of nucleus pulposus on nerve root neural activity, mechanosensitivity, axonal morphology, and sodium channel expression. *Spine* 2004;29:17-25.
73. Videman T, Battie MC, Gibbons LE, et al. Associations between back pain history and lumbar MRI findings. *Spine* 2003;28:582-8.
74. Hassett G, Hart DJ, Manek NJ, et al. Risk factors for progression of lumbar spine disc degeneration: The Chingford Study. *Arthritis Rheum* 2003;48:3112-7.
75. Moneta GB, Videman T, Kaivanto K, et al. Reported pain during lumbar discography as a function of annular ruptures and disc degeneration. A re-analysis of 833 discograms. *Spine* 1994;19:1968-74.
76. Videman T, Nurminen M. The occurrence of annular tears and their relation to lifetime back pain history: A cadaveric study using barium sulfate discography. *Spine* 2004;29:2668-76.
77. Schwarzer AC, Aprill CN, Derby R, et al. The prevalence and clinical features of internal disc disruption in patients with chronic low back pain. *Spine* 1995;20:1878-83.
78. Hamanishi C, Kawabata T, Yosii T, et al. Schmorl's nodes on magnetic resonance imaging. Their incidence and clinical relevance. *Spine* 1994;19:450-3.
79. Boos N, Rieder R, Schade V, et al. 1995 Volvo Award in clinical sciences. The diagnostic accuracy of magnetic resonance imaging, work perception, and psychosocial factors in identifying symptomatic disc herniations. *Spine* 1995;20:2613-25.
80. Lotz JC. Animal models of intervertebral disc degeneration: Lessons learned. *Spine* 2004;29:2742-50.
81. Osti OL, Vernon-Roberts B, Fraser RD. 1990 Volvo Award in experimental studies. Anulus tears and intervertebral disc degeneration. An experimental study using an animal model. *Spine* 1990;15:762-7.
82. Moore RJ, Vernon-Roberts B, Osti OL, et al. Remodeling of vertebral bone after outer annular injury in sheep. *Spine* 1996;21:936-40.
83. Walsh AJ, Lotz JC. Biological response of the intervertebral disc to dynamic loading. *J Biomech* 2004;37:329-37.
84. Issever AS, Walsh A, Lu Y, et al. Micro-computed tomography evaluation of trabecular bone structure on loaded mice tail vertebrae. *Spine* 2003;28:123-8.
85. MacLean JJ, Lee CR, Grad S, et al. Effects of immobilization and dynamic compression on intervertebral disc cell gene expression in vivo. *Spine* 2003;28:973-81.
86. Hutton WC, Ganey TM, Elmer WA, et al. Does long-term compressive loading on the intervertebral disc cause degeneration? *Spine* 2000;25:2993-3004.
87. Hutton WC, Murakami H, Li J, et al. The effect of blocking a nutritional pathway to the intervertebral disc in the dog

- model. *J Spinal Disord Tech* 2004;17:53-63.
88. Lotz JC, Colliou OK, Chin JR, et al. Compression-induced degeneration of the intervertebral disc: An in vivo mouse model and finite-element study. *Spine* 1998;23:2493-506.
 89. Kerttula LI, Serlo WS, Tervonen OA, et al. Post-traumatic findings of the spine after earlier vertebral fracture in young patients: Clinical and MRI study. *Spine* 2000;25:1104-8.
 90. Sambrook PN, MacGregor AJ, Spector TD. Genetic influences on cervical and lumbar disc degeneration: A magnetic resonance imaging study in twins. *Arthritis Rheum* 1999;42:366-72.
 91. Paassilta P, Lohiniva J, Goring HH, et al. Identification of a novel common genetic risk factor for lumbar disk disease. *JAMA* 2001;285:1843-9.
 92. Kawaguchi Y, Osada R, Kanamori M, et al. Association between an aggrecan gene polymorphism and lumbar disc degeneration. *Spine* 1999;24:2456-60.
 93. Videman T, Gibbons LE, Battie MC, et al. The relative roles of intragenic polymorphisms of the vitamin d receptor gene in lumbar spine degeneration and bone density. *Spine* 2001;26:E7-12.
 94. Takahashi M, Haro H, Wakabayashi Y, et al. The association of degeneration of the intervertebral disc with 5a/6a polymorphism in the promoter of the human matrix metalloproteinase-3 gene. *J Bone Joint Surg Br* 2001;83:491-5.
 95. Seki S, Kawaguchi Y, Chiba K, et al. A functional SNP in CILP, encoding cartilage intermediate layer protein, is associated with susceptibility to lumbar disc disease. *Nat Genet* 2005;37:607-12.
 96. Videman T, Sarna S, Battie MC, et al. The long-term effects of physical loading and exercise lifestyles on back-related symptoms, disability, and spinal pathology among men. *Spine* 1995;20:699-709.
 97. Battie MC, Videman T, Gill K, et al. 1991 Volvo Award in clinical sciences. Smoking and lumbar intervertebral disc degeneration: An MRI study of identical twins. *Spine* 1991;16:1015-21.
 98. Kelsey JL, Githens PB, White AA III, et al. An epidemiologic study of lifting and twisting on the job and risk for acute prolapsed lumbar intervertebral disc. *J Orthop Res* 1984;2:61-6.
 99. *Oxford English Dictionary*. Oxford University Press. Available at: <http://www.oed.com>.
 100. Le Maitre CL, Freemont AJ, Hoyland JA. Localization of degradative enzymes and their inhibitors in the degenerate human intervertebral disc. *J Pathol* 2004;204:47-54.
 101. Le Maitre CL, Freemont AJ, Hoyland JA. The role of interleukin-1 in the pathogenesis of human intervertebral disc degeneration. *Arthritis Res Ther* 2005;7:R732-45.
 102. Riley GP, Curry V, DeGroot J, et al. Matrix metalloproteinase activities and their relationship with collagen remodelling in tendon pathology. *Matrix Biol* 2002;21:185-95.
 103. Anderson DG, Li X, Tannoury T, et al. A fibronectin fragment stimulates intervertebral disc degeneration in vivo. *Spine* 2003;28:2338-45.
 104. Nissi MJ, Toyras J, Laasanen MS, et al. Proteoglycan and collagen sensitive MRI evaluation of normal and degenerated articular cartilage. *J Orthop Res* 2004;22:557-64.
 105. Melrose J, Roberts S, Smith S, et al. Increased nerve and blood vessel ingrowth associated with proteoglycan depletion in an ovine annular lesion model of experimental disc degeneration. *Spine* 2002;27:1278-85.
 106. Johnson WE, Caterson B, Eisenstein SM, et al. Human intervertebral disc aggrecan inhibits nerve growth in vitro. *Arthritis Rheum* 2002;46:2658-64.
 107. Johnson WE, Caterson B, Eisenstein SM, et al. Human intervertebral disc aggrecan inhibits endothelial cell adhesion and cell migration in vitro. *Spine* 2005;30:1139-47.
 108. Ishihara H, McNally DS, Urban JP, et al. Effects of hydrostatic pressure on matrix synthesis in different regions of the intervertebral disk. *J Appl Physiol* 1996;80:839-46.
 109. Handa T, Ishihara H, Ohshima H, et al. Effects of hydrostatic pressure on matrix synthesis and matrix metalloproteinase production in the human lumbar intervertebral disc. *Spine* 1997;22:1085-91.
 110. Thompson JP, Pearce RH, Schechter MT, et al. Preliminary evaluation of a scheme for grading the gross morphology of the human intervertebral disc. *Spine* 1990;15:411-5.
 111. Pfirrmann CW, Metzendorf A, Zanetti M, et al. Magnetic resonance classification of lumbar intervertebral disc degeneration. *Spine* 2001;26:1873-8.
 112. Freemont AJ, Watkins A, Le Maitre C, et al. Current understanding of cellular and molecular events in intervertebral disc degeneration: Implications for therapy. *J Pathol* 2002;196:374-9.
 113. Fardon DF. Nomenclature and classification of lumbar disc pathology. *Spine* 2001;26:461-2.
 114. Solovieva S, Lohiniva J, Leino-Arjas P, et al. COL9A3 gene polymorphism and obesity in intervertebral disc degeneration of the lumbar spine: Evidence of gene-environment interaction. *Spine* 2002;27:2691-6.

Sidebar: Key Points

- Intervertebral disc degeneration needs to be defined for scientific and medicolegal reasons.
- We propose the following working definition to stimulate further discussion: disc degeneration is an aberrant cell-mediated response to progressive structural failure.
- Disc structural failure is irreversible, always progresses by physical and biologic mechanisms, and is closely associated with mechanical dysfunction and pain.
- Genetic inheritance, age, inadequate metabolite transport, and loading history can weaken discs to such an extent that structural failure occurs during the activities of daily living.

Funding Information

Federal funds were received in support of this work. No benefits in any form have been or will be received from a commercial party related directly or indirectly to the subject of this manuscript.

Reprint Address

Michael A. Adams, PhD, Department of Anatomy, University of Bristol, Southwell Street, Bristol BS2 8EJ, United Kingdom;
E-mail: M.A.Adams@bris.ac.uk

Michael A. Adams, PhD,* and **Peter J. Roughley, PhD[†]**

*Department of Anatomy, University of Bristol, Bristol, United Kingdom, and [†]Shriners Hospital, Montreal, Canada.
